

Why Electromechanical Actuators are Increasingly Replacing Hydraulic Systems

Executive Summary

Hydraulics have traditionally provided much of the muscle for the industrial revolution, but that functionality has come with a cost. Hydraulic systems are complicated and messy, labor-intensive and space-consuming, and expensive to operate and maintain. For many years, these systems have been the only option for several applications. Today, however, advanced electromechanical linear actuators offer a high-volume, high-strength solution that is simpler, cleaner and more controllable than their hydraulic counterparts. This is becoming increasingly critical as the industrial world migrates from internal combustion engines to battery operated vehicles, where hydraulics are impractical. If you typically specify hydraulic systems for your machine and equipment designs, this white paper examines several reasons to consider electromechanical alternatives.

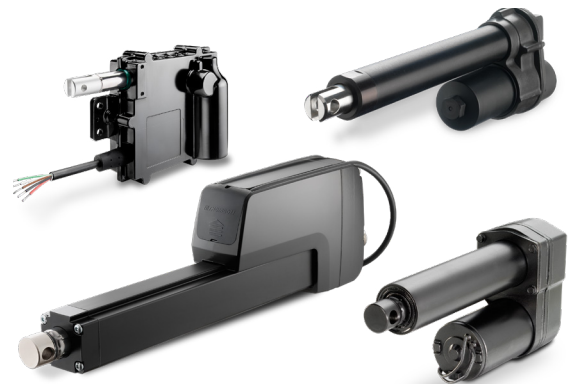

Hydraulic Systems are Complicated, Unwieldy and Noisy

In a hydraulic system, barely compressible hydraulic fluid amplifies electrical energy to move a load. In a typical dual-action hydraulic system, an electric motor drives a pump, which delivers the incompressible hydraulic oil to a cylinder containing a tightly sealed, but easily movable, piston attached to a piston rod. As the intake fluid arrives from the reservoir, it exerts pressure on the piston rod, which moves the load. And as the piston moves, it forces fluid out the other end of the cylinder to the reservoir for eventual return to the chamber.

Supporting this complex process requires an external system of hoses, connectors, filters, switches, valves and pumps that cycle the fluid to and from the cylinder, enabling movement. (Figure 1) This repeats for every axis of motion. Even the smallest system would require at least eight separate moving

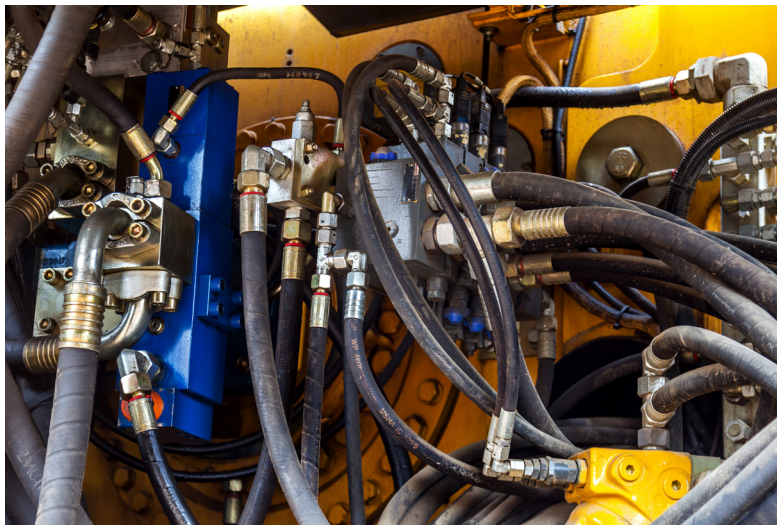

Figure 1. In contrast to electromechanical actuators, hydraulic systems are complicated due to the requirement of hoses, connectors, valves, filters and switches to operate.

components, which introduces a higher-than-average risk of system failure. Maintaining consistent pressure is critical, and that depends on proper valve settings, connections and switching.

In addition to the effort taken to synchronize and maximize the performance of so many moving parts, hydraulic systems consume valuable space, which is increasingly important as machine designs – both mobile and stationary – are becoming smaller and smaller. Noise is an issue as well. Even with the system operating at peak performance, motors, pumps

and other components provide a steady serving of distracting noise. To reduce the noise, some users are resorting to noise mitigation products and services, which add even more design challenges and costs.¹

Most applications that involve hydraulics require multiple cylinders. The more cylinders in use, the greater the complexity, ambient noise, energy consumption and related costs.

In contrast, the simplicity of electromechanical systems makes them much more manageable. Where hydraulic systems require the infrastructure of hoses, connectors, valves, filters and switches to translate energy into motion, electromechanical systems use only a few wires. They are easier to install, consume less space and add minimal weight to the overall motion system. (Figure 2)

Hydraulic Systems are Messy, Dangerous and High Maintenance

While the complexity of hydraulic systems can get expensive in terms of space utilization, noise mitigation and energy consumption, there is an additional layer of maintenance related to the characteristics of hydraulic fluid itself. There are several different types of fluid used, and all require special handling because they are potentially grimy, smelly, slippery and hazardous. (Figure 3) The following are some of the potential hydraulic fluid handling issues that have been identified:

Toxicity. The U.S. Agency for Toxic Substances and Disease Registry reports that some types of hydraulic fluids can irritate skin or eyes and that ingesting certain types can cause pneumonia,

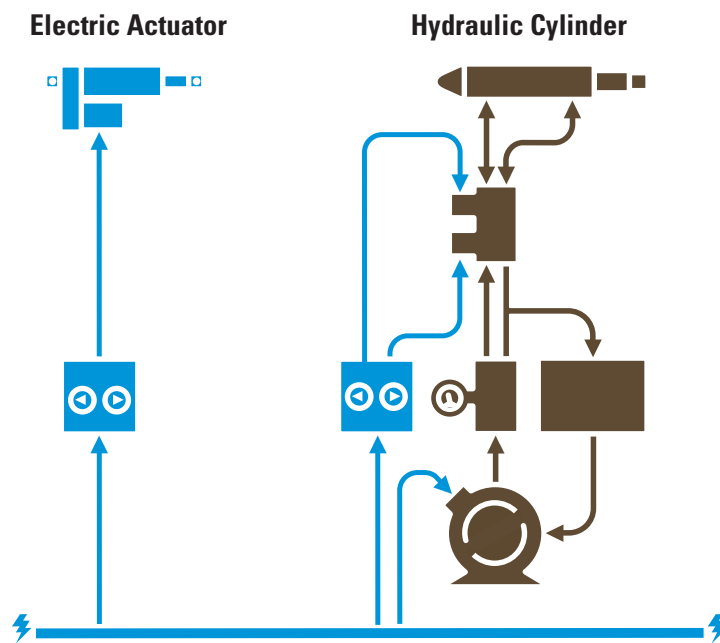

Figure 2. Detailed illustration comparing electromechanical actuators and hydraulic system architectures. Electromechanical actuators embed all necessary functionality.

intestinal bleeding or death in humans. It also says that swallowing or inhaling certain types of hydraulic fluids has caused nerve damage in animals.²

The potential for toxicity is of special concern for linear motion in food-related applications. Exposure to hydraulic leakage in robotic grape-picking equipment, for example, threatens both the purity and taste of the related wine.

The effects of breathing air with high levels of hydraulic fluids are not known, but some countries have set

hydraulic fluid exposure limits. For example, the U.S. Occupational Safety and Health Administration (OSHA) has set an exposure limit of 2,000 milligrams per cubic meter (mg/m³) of petroleum distillates for an 8-hour workday and 40-hour workweek.³ The National Institute for Occupational Safety and Health (NIOSH)

recommends an even stricter exposure limit of 350 mg/m³ of petroleum distillates for a 10-hour workday and 40-hour workweek.

Contamination.

In addition to being potentially toxic to humans, hydraulic fluids can be harmful to the environment. The U.S. Environmental Protection Agency (EPA), for example, includes hydraulic fluids on its list of oils that require special handling.



Figure 3. Hydraulic systems use various types of fluid that can be messy, slippery and hazardous to humans and the environment. As hydraulic fluids lose effectiveness over time, special care and regular maintenance is critical.

Slip and fall. Fluid leaking from systems or spilled during maintenance can present slip-and-fall hazards. There are many reported cases of workers who have been injured by slipping on puddles of leaked fluid or falling while climbing up onto their machines with oil on their hands or shoes.⁴

Burn hazards. During routine operation, hydraulic systems can reach as high as 180 degrees Fahrenheit, but some can go significantly higher than that, reaching temperatures that can cause severe skin burns, while also heating metal components to dangerous levels.⁵

Cleanup. Indoor spills may also be subject to local regulation or require additional investment in absorbent substances or other cleanup services.⁶

Combustibility. Petroleum-based hydraulic fluids are less flammable than petroleum middle distillate fuels such as jet fuel, kerosene or diesel fuel. These can be a fire hazard if sprayed, as might happen when high-pressure leaks convert the fluid to an aerosol state.⁷

Because of such messiness and toxicity, hydraulic fluid requires



Figure 4. The complexity of hydraulic systems leads to not only difficult, error-prone installations but the likelihood of increased maintenance and associated costs.

special care during storage and fluid changes. As hydraulic oil is pumped through the system, filters may clog, oil levels may drop, and bearings, seals and gears may deteriorate – all of which can contribute to leakage, noise and other problems. These issues, which include valves not opening or closing properly, changes in oil viscosity, and oil overheating, are addressable but jeopardize reliability.

Since hydraulic fluids degrade and lose effectiveness over time, they must be replaced regularly, which requires maintaining an inventory, adding costs and presenting additional potential for spillage. This also means that someone must coordinate the checking of filters and oil integrity to determine when to change the fluids.⁸ (Figure 4) Neglecting to change oil and filters will shorten machine life and lead to unplanned downtime, increase negative environmental impact, and shorten planned maintenance intervals.

Electromechanical actuators, on the other hand, are much cleaner because they use electrical energy rather than messy hydraulic fluids. (Figure 5) They require minimal lubrication, and some units use self-lubricating components that eliminate the need

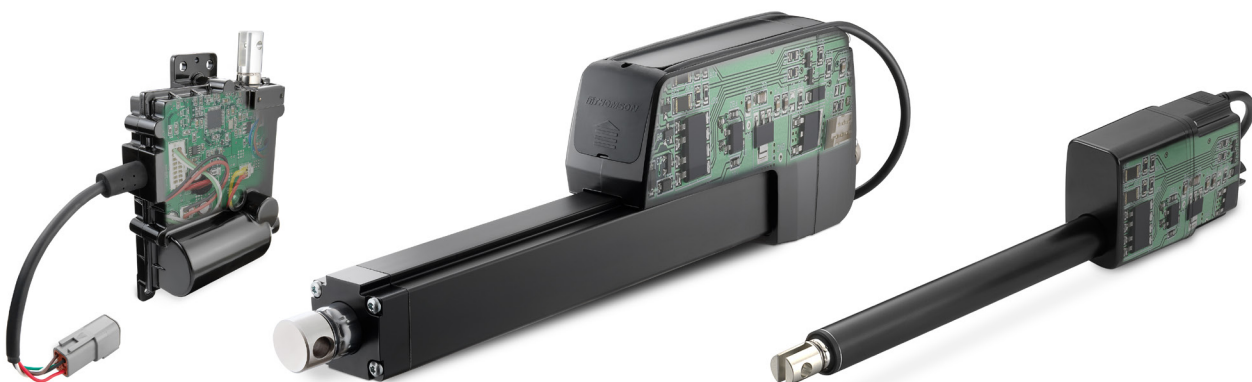
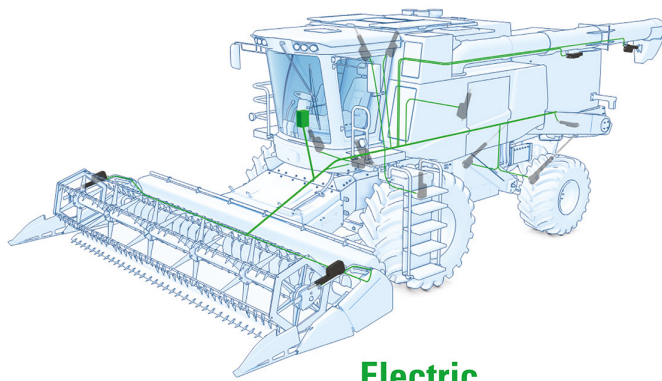
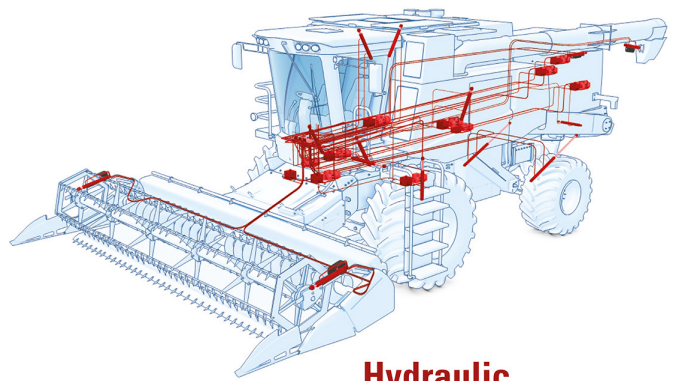

Figure 5. Using integrated programmable circuit boards (PCBs), electromechanical actuators are capable of providing a wide range of enhanced control and diagnostic options.



Electric



Hydraulic

Figure 6. Electromechanical and hydraulic wiring comparison.

for maintenance altogether. Plus, systems can be configured to minimize friction, which increases duty cycles significantly.

Hydraulic Systems are Difficult to Control

Because hydraulic cylinders are designed only for simple end-to-end movements, instructing one to stop at a certain position, change location or attain a specified speed requires adding control components.

Likewise, ramping speed up, slowing down or following a consistent motion profile would require external components, which can be expensive to integrate, operate and maintain. Obtaining accurate position readings, for example, would require an external measuring device such as a rotary encoder. Speed control would require sophisticated valve assemblies.

In electromechanical actuators, by contrast, all such functionality can be embedded in the actuator housing itself, which connects an electronic control unit (ECU) with one or two wires. (Figure 6) Leveraging this capability are built-in microprocessors that can be programmed to report position, provide diagnostic feedback that improves performance, and handle complex functions like synchronizing multiple actuators. (Figure 7)

Electromechanical actuators can also accept commands and, in

return, provide performance- and safety-related status such as position, speed, temperature or dynamic load. When outfitted with strain gauges, the actuator can also monitor static load, which can help prevent starting an overloaded system. And because functionality can be switched on instantly, there is none of the noisy, costly system idling.

Below are some of the control and integration capabilities that are easy to achieve with electromechanical systems while challenging – if possible, at all – with hydraulic cylinders.

Closed loop control. Electromechanical actuators can use microcontrollers, digital signal processors (DSPs) and other technology that can enable fine tuning of actuator behavior with complex algorithms, such as Proportional-Integral-Derivative (PID) control schemes based on high-resolution position input from encoders.

Programmability. Motion system designers can program electromechanical actuators to perform specific motion profiles, controlling acceleration, deceleration and dwell times, which are difficult to achieve with hydraulic systems.

Integration. Electromechanical actuators integrate easily with external control systems such as Programmable Logic Controllers

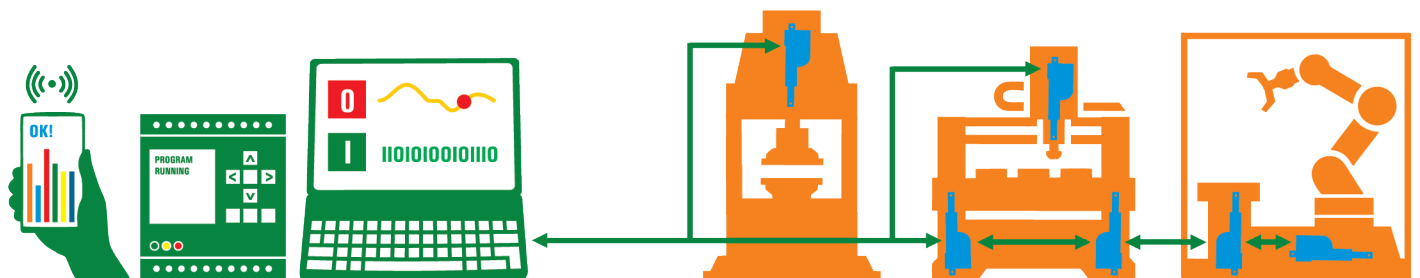

Figure 7. Bus control, remote diagnostics, real-time monitoring and adjustment, among many other advanced control features, allow electromechanical actuators to streamline automation for factories of all sizes and varieties.

Comparing Electromechanical Actuators and Hydraulic Systems

	Electromechanical	Hydraulic
Footprint/Installation	All functionality is built in; mounts with just a few bolts	Requires external support infrastructure, pumps, valves, etc.
Cleanliness/Safety	Zero environmental contamination or leakage; compact design is leaner to manufacture	Fluid leakage and spill issues; numerous sub-components have high resource requirements; potential hazard ¹⁰
Maintenance	Negligible; programmable end-of-stroke limits extend life	Pumps, valves and hoses require attention; components may have to be resized or changed out; fluid must be replaced, and leaks repaired
Noise	Silent while both idle and moving loads	Higher noise levels due to pumps, air pressure or fluids during operation and idling
Control	Multiple digital and analog options; low-voltage switching; pulse-width modulation	Minimal capability; requires even more external instrumentation
Static Load Handling	Hold power with off; no drift	Requires pump, but drift still high
Shock Load Handling	Can be ordered with shock-absorbing elastomeric bushings	Hydraulic fluid absorbs shock
Energy Efficiency	Consumes less energy, up to 80% efficient; high power density	About 20% efficient during operation; draws power while idling
Cost	Longer component life, high redundancy, efficient battery operation, little to no maintenance and low energy consumption reduce cost	Energy inefficient; draws power whether in use or not; requires costly, high-maintenance support infrastructure

(PLCs) and Computer Numerical Control (CNC) systems, which are common in automation environments. This integration allows for synchronized control of multiple actuators, improving overall system performance.

Dynamic response. Electromechanical actuators can offer faster response times and smoother operation because they are directly controlled by electronic signals, where hydraulic systems may lag due to fluid inertia and compressibility.

Rotation control. Electromechanical actuators can integrate stepper and servo motors to enable more precise control over rotational movements.

Fine tuning of current and voltage. Precision motor drivers control the electrical input to the motors, allowing for fine adjustments to motor torque and speed, which directly translates into better control of the actuator's motion.

Stable low-speed operation. High control over current enables electromechanical actuators to maintain stability and control even at extremely low speeds, whereas hydraulic systems can struggle

with stability and control at low velocities due to fluid dynamics.

Direct relationship between input and output.

Electromechanical actuators have a more linear and predictable response to input signals compared to hydraulic systems, where the response can be non-linear and influenced by factors such as fluid compressibility, temperature and leakage.

Adaptive control. Electromechanical actuators adapt to changes in load or environmental conditions, ensuring consistent performance without requiring manual adjustments.

Additionally, features such as programmable end-of-stroke limits enhance efficiency, extend the lifespan of the components, and reduce the risk of failures and unanticipated downtime.

Hydraulic Systems are Less Energy Efficient

To maintain adequate pressure to hold a static load in place, hydraulic systems must remain idling, making them inefficient energy consumers. This is especially true when the system must hold a static load in place, as can be the case for mobile equipment.⁹

Traditionally, this energy efficiency has not been an issue for hydraulic systems, which usually rely on a diesel engine to generate power. Although they do so with only about 20% efficiency, it has been more than required for the simple operations they perform. But as mobile vehicles become more prevalent, energy efficiency becomes more important. Batteries are expensive, heavy and need regular charging, making extending battery life critical.

Electromechanical actuators are much more cost effective for mobile vehicles, especially those that are driver-less. Embedded electronics deliver low power signals on demand where needed. Electromechanical actuators can also generate additional power for return to other devices.

Proven Pain Relief

Electromechanical linear actuators have advanced to provide the high-load (up to 60 kN), compact advantages of hydraulics but without the drawbacks. It is now possible to get precise, closed-loop control of linear and rotary motion without the oil leaks, infrastructure and rigidity of hydraulic systems. And when designers choose a mechanical shock-dampening option, electromechanical actuators will have even longer lifetimes in applications subject to axial shock loads.

As actuator technology advances to handle additional axes, nodes and power, the benefits of electromechanical actuators become more pronounced while the capabilities of hydraulic systems become less necessary. That is why designers of mobile equipment, automated industrial machinery, aerospace systems and agricultural applications are increasingly replacing hydraulic systems with electromechanical linear actuators whenever they need simple, powerful and smart actuation.

Thomson Industries, Inc. offers a full selection of smart electromechanical linear actuators to match the requirements of various applications. Visit www.thomsonlinear.com/la for details.

References

¹ Brendan Casey (2019), *Symptoms of Common Hydraulic Problems and their Root causes*. Retrieved from: <https://www.machinerylubrication.com/Read/531/hydraulic-root-causes>

² Agency for Toxic Substances and Disease Registry, Public Health Service, U.S. Department of Health and Human Services, Public Health Service in Atlanta, GA. *Toxicological Profile for Hydraulic Fluids (1997)* Retrieved at: <https://www.atsdr.cdc.gov/toxfaqs/tf.asp?id=756&tid=141>

³ United States Department of Labor, Occupational Safety and Health Administration. *Air contaminants*. Retrieved at: <https://www.osha.gov/laws-regs/regulations/standardnumber/1915/1915.1000>

⁴ Joseph Hrinik (2007) *Hydraulic Fluid Hazards*. Retrieved at: <https://www.forkliftaction.com/news/newsdisplay.aspx?nwid=4584>

⁵ J. Eric Freimuth (2017) *Did you know that hydraulic fluids can kill?* Retrieved at: <https://www.linkedin.com/pulse/did-you-know-hydraulic-fluids-can-kill-j-eric-freimuth/>

⁶ Agency for Toxic Substances and Disease Registry, Public Health Service, U.S. Department of Health and Human Services, Public Health Service in Atlanta, GA. *Toxicological Profile for Hydraulic Fluids (1997)* Retrieved at: <https://www.atsdr.cdc.gov/toxfaqs/tfacts99.pdf>

⁷ George W. Mushrush, Heather D. Willauer, Jean L. Bailey, John B. Hoover & Frederick W. Williams (2006) *Petroleum-Based Hydraulic Fluids and Flammability*, *Petroleum Science and Technology*, 24:12, 1441-1446, Retrieved at: <https://www.tandfonline.com/doi/abs/10.1081/LFT-200056782>

⁸ W.D. Phillips (2006) *The High-Temperature degradation of hydraulic oils and fluids*. Retrieved at: <https://www.hyprofiltration.com/clientuploads/directory/Knowledge/PDFs/High%20Temp%20Degradation%20of%20Hydraulic%20Oils%20%20Fluids.pdf>

⁹ Milos Vukovic, Hubertus Murrenhoff (2015) *The Next Generation of fluid power systems*. Retrieved at: https://www.researchgate.net/publication/283085606_Mobile_Working_Hydraulic_System_Dynamics

¹⁰ Yao, Z., Tang, J., Rui, T., & Duan, J. (2017). *A time-frequency analysis based internal leakage detection method for hydraulic actuators*. *Advances in Mechanical Engineering*. Retrieved at: <https://doi.org/10.1177/1687814016685058>